

Type 1FU SS-Cartridge Filter Housing

The filter housings of 1FU series are cartridge filter housings to install a DOE filter cartridge or an adaptor filter cartridge (Code 8). The housings are designed so that all commonly used filter cartridge lengths can be assembled. The connections (N3/N4) allow the attachment of a differential pressure gauge. Wall mounting bracket and opening wrench are optional.

TECHNICAL DATA

1FU

Max. pressure at 80°C	25 bar
Material filter head	AISI 304 / AISI 316
Material sump	AISI 304 / AISI 316
Material cartridge adaptor	AISI 304 / AISI 316
Material gaskets	FPM O-ring*
Material gaskets (N3/N4)	KLINGERSIL® C-4400
Vent / Manometer (N3/N4)	Rp 1/4" with plug
IN / OUT (N1/N2)	Rp 1"
Drain (N5)	Rp 3/8"
Deliverable lengths	5", 10", 20" und 30"

* also available in other gasket materials

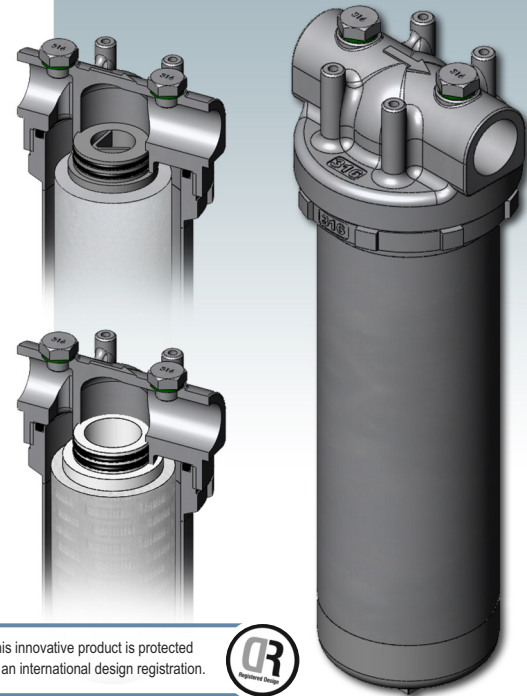

This innovative product is protected with an international design registration.



Installation situation with SOE-filter cartridge (Code 8) without adaptor

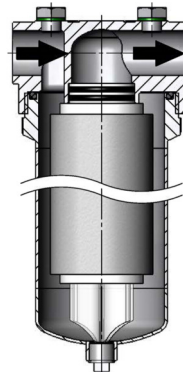

Installation situation with DOE-filter cartridge incl. support adaptor

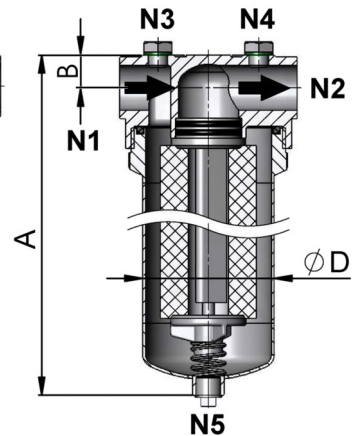

ORDERING INFORMATION

1FU

1FU1-25/25-A2F	
Type 1FU = Cartridge Filter Housing	Gaskets N = NBR F = FPM E = EPDM
Cartridge Length 0 = 124 bis 128 mm or 222-05" 1 = 248 bis 254 mm or 222-10" 2 = 496 bis 508 mm or 222-20" 3 = 762 mm or 222-30"	Material A2 = 1.4301 (AISI 304) A4 = 1.4401 (AISI 316)
Max. Pressure 25 = 25 bar	Connections 25 = Rp 1" (DIN 2999)

DIMENSIONS

Type	Dimensions (mm)						
	A	B	C	D	E	F	G
1FU0	230	22	120	ø88,9	62	42	68
1FU1	367	22	120	ø88,9	62	42	68
1FU2	615	22	120	ø88,9	62	42	68
1FU3	863	22	120	ø88,9	62	42	68

Mounting bracket with screws and washers



Opening wrench



Subject to technical alterations.
AL1059-01-E