

acuraLine®

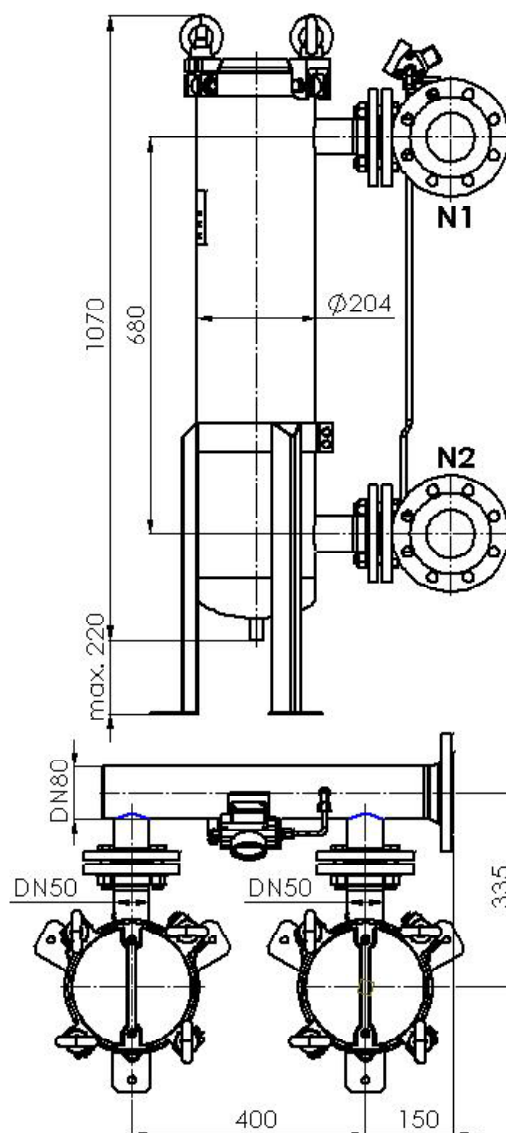

DUPLEX - FILTER ALGS2-DN50 x DN80

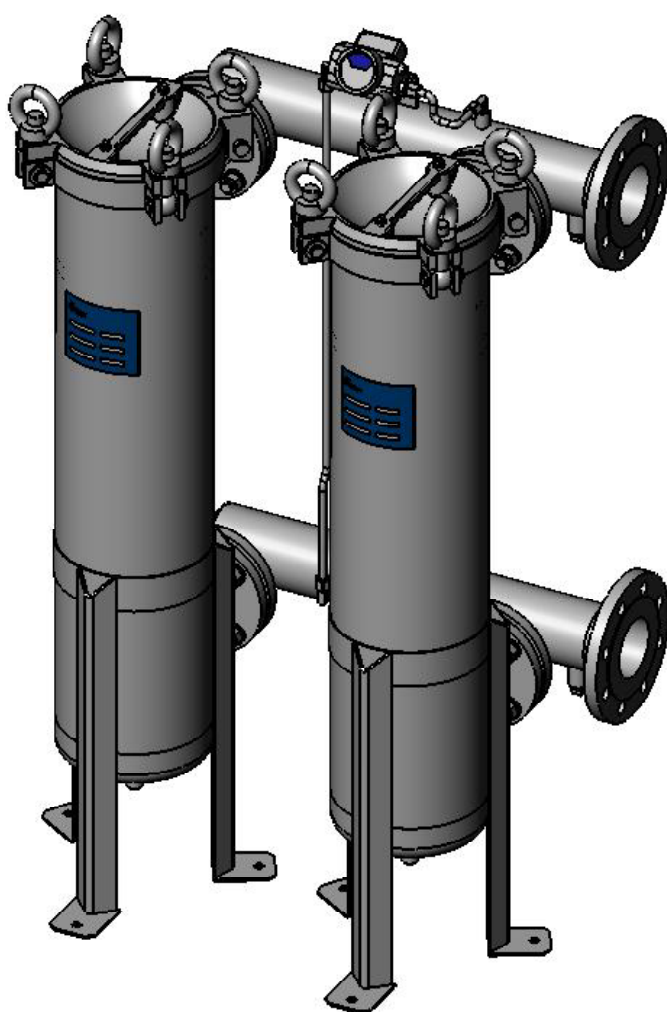

TECHNICAL DATA

Max. allow. pressure	: 10 bar
Max. allow. temperature	: -10/+80°C
Max. Flowrate	: 50 m ³ /h with water and 100 µm filtration rate
Material	: AISI 304 (1.4301) or AISI 316 (1.4401)
Gasket Material	: NBR O-Ring, optional also EPDM or FPM
Inlet / Outlet (N1 + N2)	: Flange DN80 PN16, DIN 2633
Drain	: 2 x R 1/2" male
Venting	: 2 x G 1/4" female
Differential pressure gauge	: optional

AL230701