

**DOE FILTER CARTRIDGE
(DOUBLE-OPEN-END)**

**ADAPTOR FILTER CARTRIDGE
(CODE 8)**

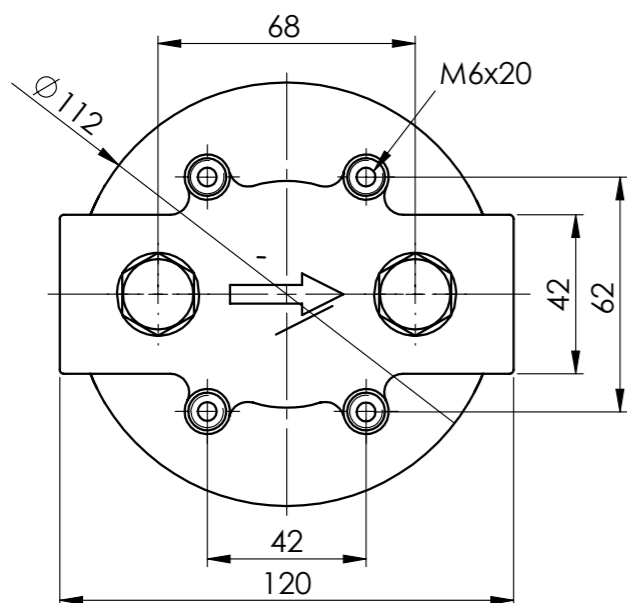
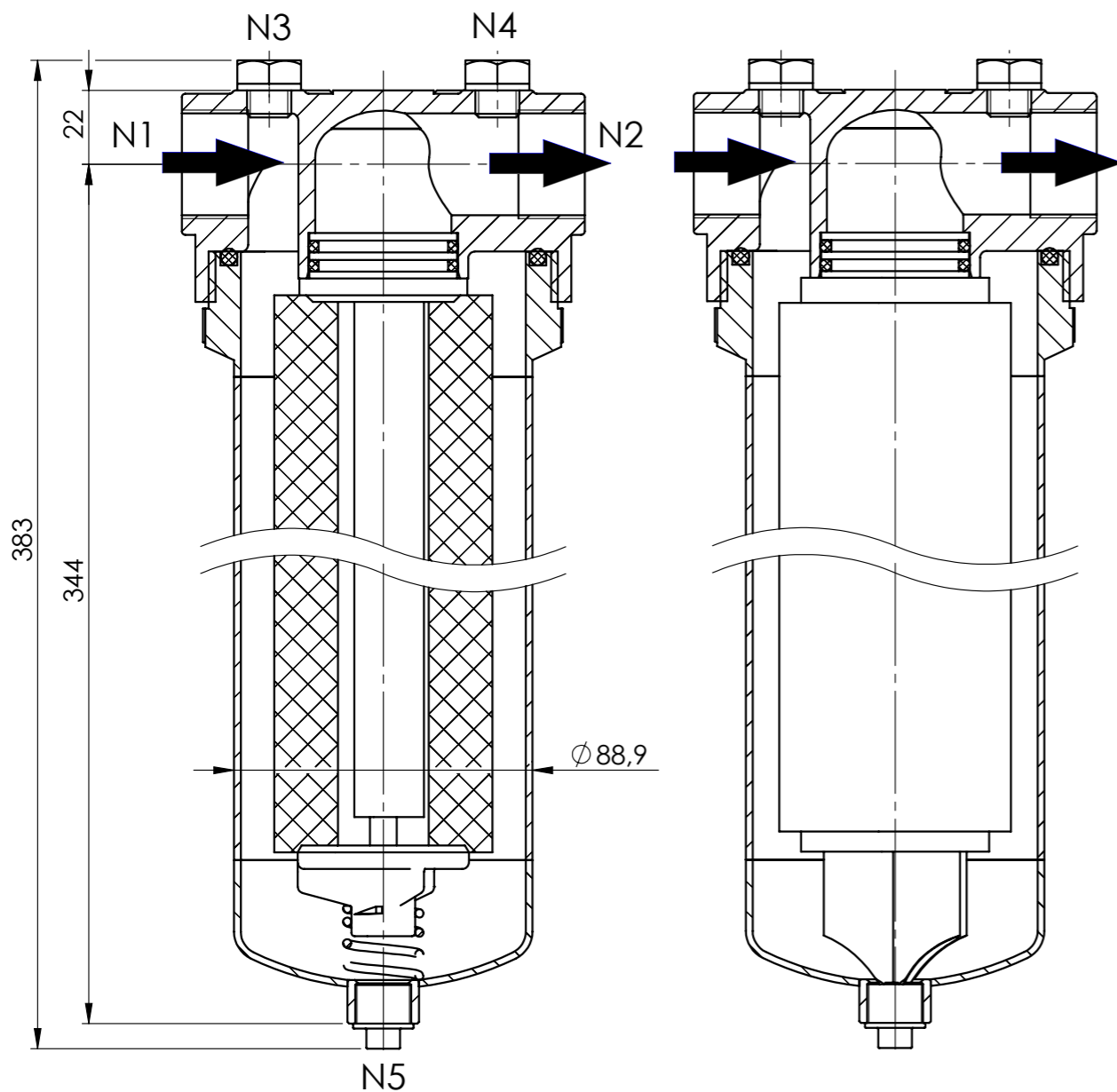

NOZZLE INDEX

Connection	Size	Type	DIN
N1	Rp 1	Inlet	DIN 2999
N2	Rp 1	Outlet	DIN 2999
N3	Rp 1/4	Vent	DIN 2999
N4	Rp 1/4	Vent	DIN 2999
N5	Rp 3/8	Drain	DIN 2986

SPECIFICATION

Max. allow. pressure	25 bar
Max. allow. temperature	-10/+80°C
Volume	2 l
Material Filter Head	AISI 304
Material Filter Sump	AISI 304
Material Insert	AISI 304
Material Gasket	FPM
DOE - Cartridge Length	248 - 254 mm
Adapter Cartridges	10 inch - CODE 8
Weight	3,6 kg

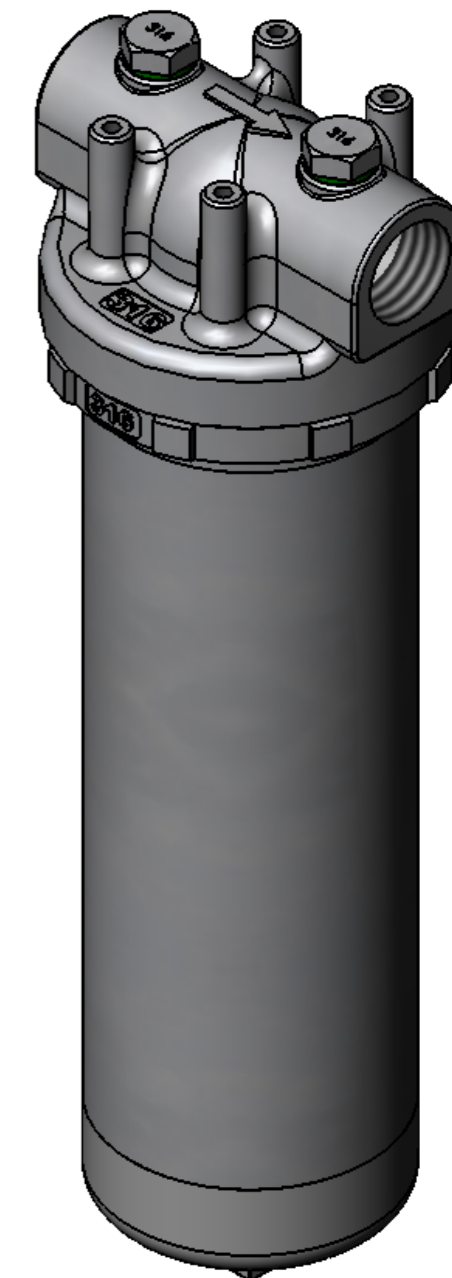

analog fig

Date	14.02.2012	Name	Brixius	Type	1FU1-25/25-A2F	
Proof.						
Resp.						
Norm						
					Article-No.	1754112025
Am Weinkastell 14 55270 Klein-Winternheim					acc. drawing: 10-1269	Repl. for.